

ITEM NO.	QTY.	DESCRIPTION	LENGTH	ANGLE1	ANGLE2
1	8	Al Tube 2x1x0.125	179 3/4"	45	45
2	16	Al. Angle 2" x 2" x 1/4"	20 3/4"	0	0
3	8	Al Tube 1x1x0.125	24 1/4"	46	46
4	4	Al. Tube 1x1x1/8	175 3/4"	0	0
5	12	Al Tube 1x1x0.125	5"	0	0
6	28	Al Tube 2x1x0.125	9"	45	45
7	8	Al Tube 1x1x0.125	8"	45	45
8	6	3 1/8" ABC Divider Extrusion	175 3/4"	-	-
9	4	Wire Track	177 3/4"	0	45
10	17	Al Tube 1x1x0.125	22 7/16"	0	0
11	4	Al Tube 1x1x0.125	198 11/16"	26	26
12	2	Wire Track	96 3/4"	45	45
13	1	Al Tube 2x1x0.125	24 1/2"	0	0
14	23	Al Tube 2x1x0.125	20 3/4"	0	0
15	8	Al Tube 2x1x0.125	7 1/2"	45	45
16	1	Al Tube 2"x2"x1/8"	20 3/4"	0	0
17	2	3 1/8" ABC Divider Extrusion	32 3/8"	-	-

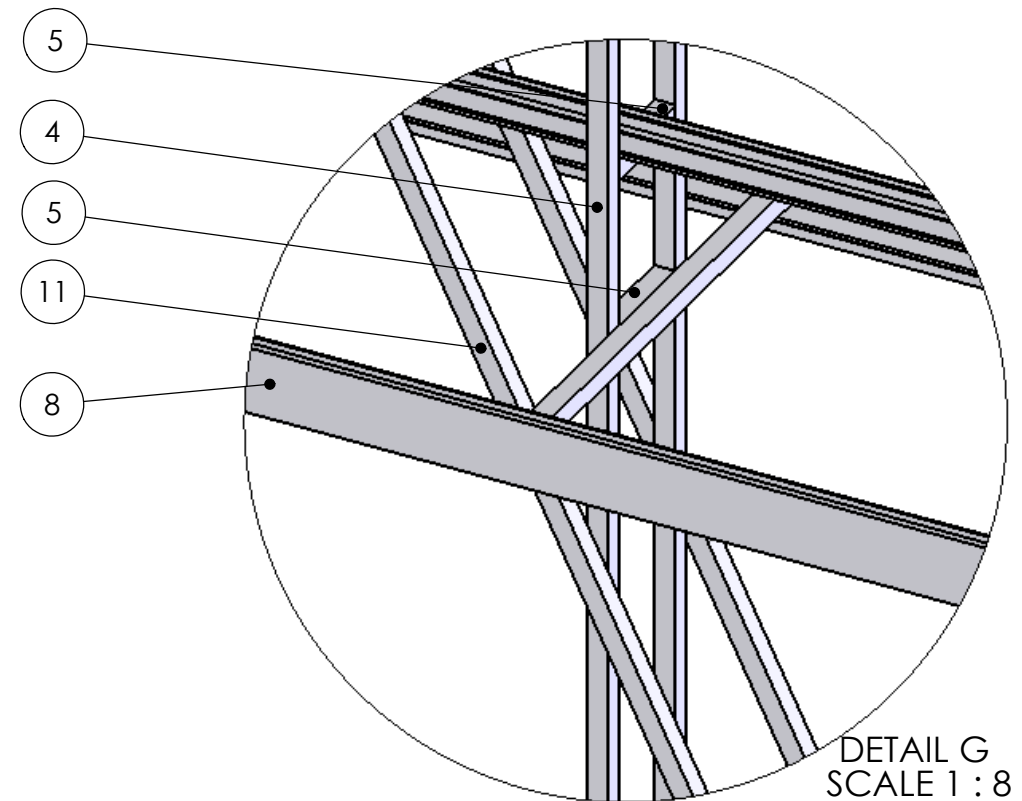
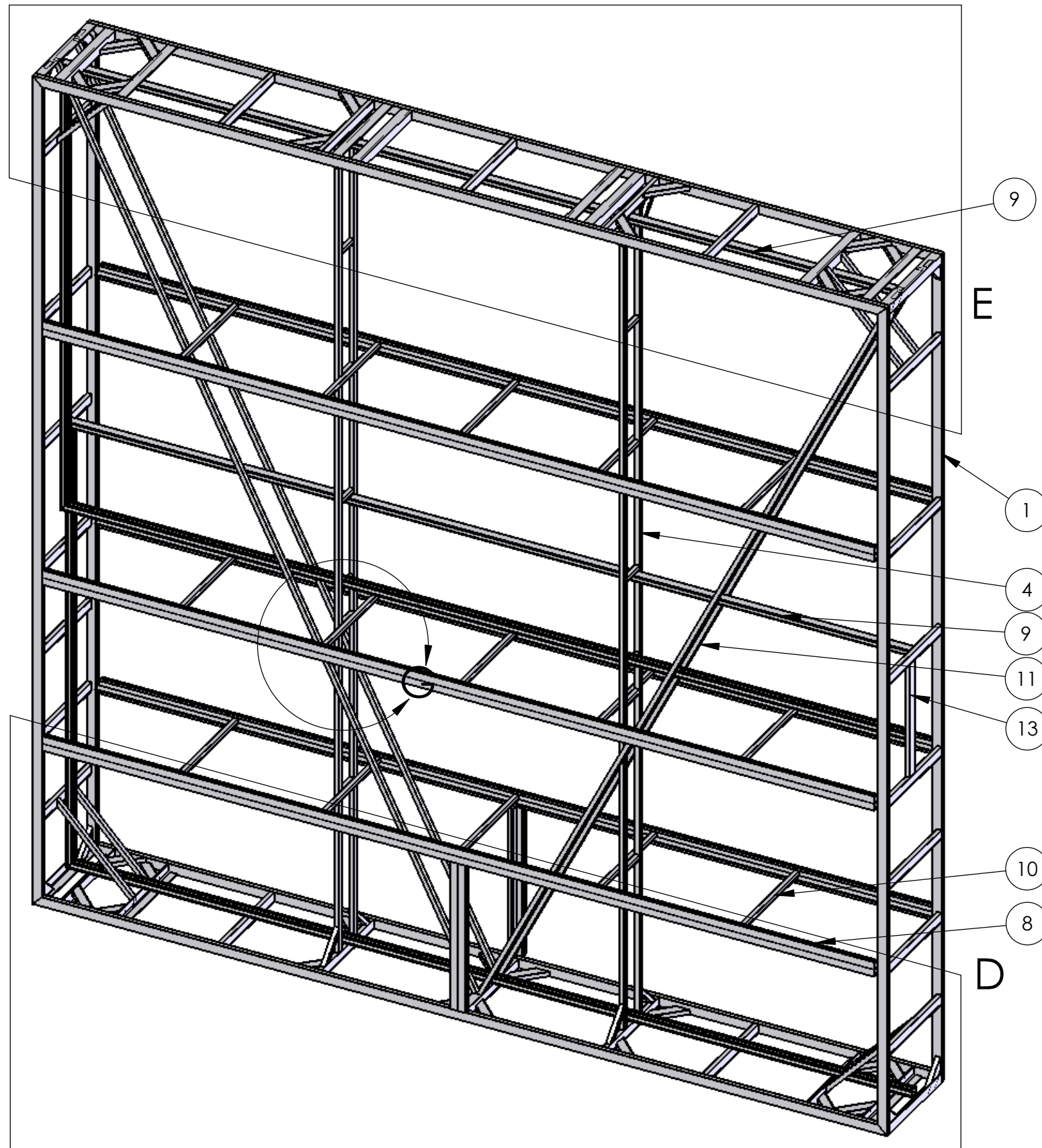

PROPRIETARY AND CONFIDENTIAL

This is an original unpublished drawing which is the sole and exclusive property of Sparkle Sign Company, Inc. and is protected under the copyright laws of the United States of America. It was created in conjunction with a project proposed by Sparkle Sign Company, Inc. It is not to be reproduced, duplicated, shown, exhibited, or physically re-created in whole or in part by any individual, group, organization, or entity without the written permission of an officer of Sparkle Sign Company, Incorporated.

DIMENSIONS ARE IN INCHES		NAME	DATE	Designed exclusively for: CYPRESSWOOD LANDING
TOLERANCES:		DRAWN	Mohsen	
FRACTIONAL ±		CHECKED		Title: Structure
ANGULAR: MACH ± BEND ±		ENG APPR.		
TWO PLACE DECIMAL ±		MFG APPR.		
THREE PLACE DECIMAL ±		Q.A.		
MATERIAL --		COMMENTS:		
NEXT ASSY	USED ON			
FINISH --				
APPLICATION	DO NOT SCALE DRAWING			
SIZE	DWG. NO.	REV.		
B	C7559-B-01-00			
SCALE: 1:24	WEIGHT:	SHEET 1 OF 4		

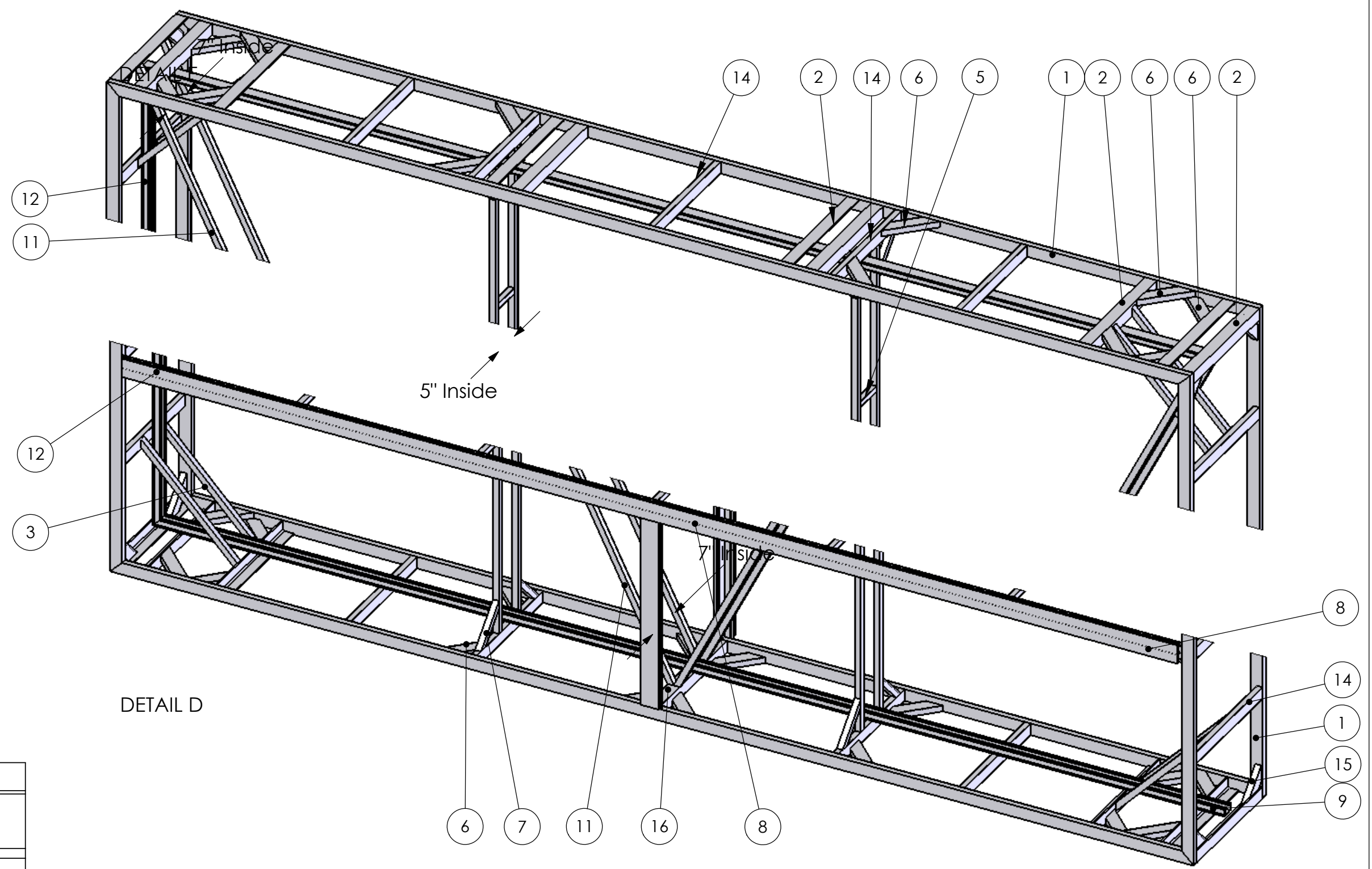
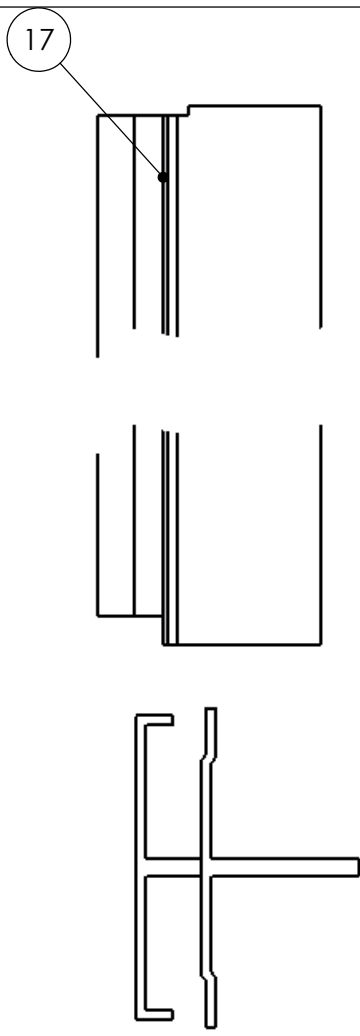

DETAIL D

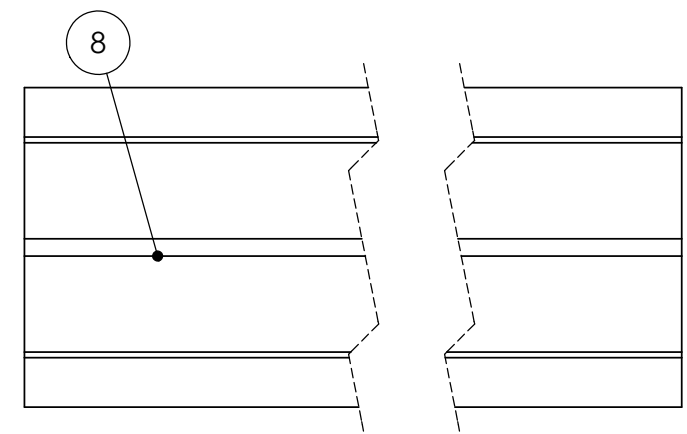

The length of the Divider Bars and edge cut may change with the type of the Retainer.



PROPRIETARY AND CONFIDENTIAL
This is an original unpublished drawing which is the sole and exclusive property of Sparkle Sign Company, Inc. and is protected under the copyright laws of the United States of America. It was created in conjunction with a project proposed by Sparkle Sign Company, Inc. It is not to be reproduced, duplicated, shown, exhibited, or physically re-created in whole or in part by any individual, group, organization, or entity without the written permission of an officer of Sparkle Sign Company, Incorporated.

		DIMENSIONS ARE IN INCHES TOLERANCES: FRACTIONAL ± ANGULAR: MACH ± BEND ± TWO PLACE DECIMAL ± THREE PLACE DECIMAL ±		NAME	DATE	Designed exclusively for: CYPRESSWOOD LANDING
		MATERIAL --		MOHSEN	03/01/06	
		FINISH --		ENG APPR.		Title: Structure
		NEXT ASSY USED ON		MFG APPR.		
APPLICATION		DO NOT SCALE DRAWING		COMMENTS:		SIZE DWG. NO. C7559-B-01-00 REV. SCALE: 1:16 WEIGHT: SHEET 2 OF 4

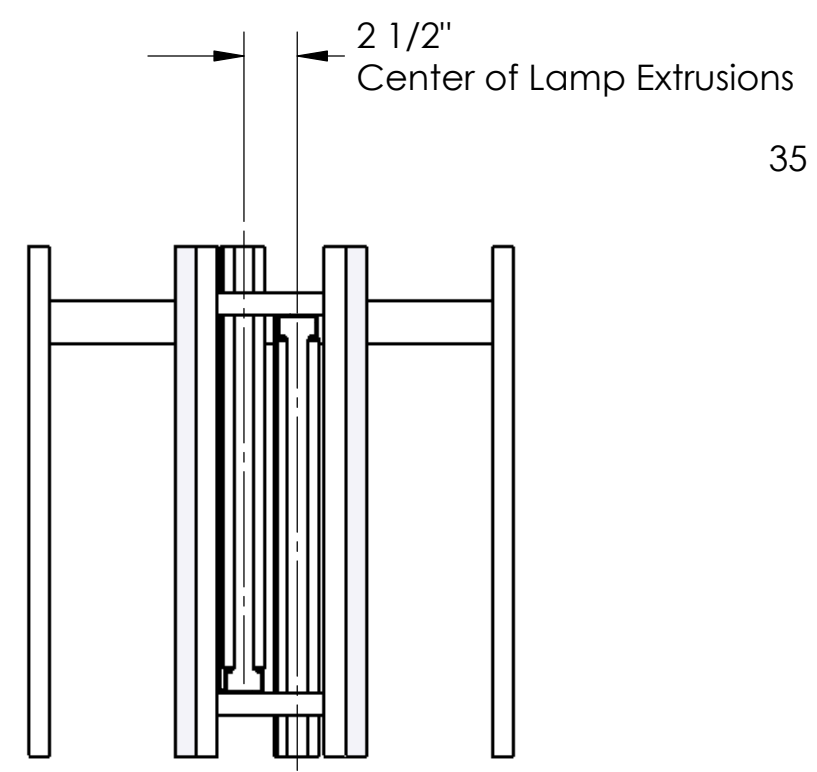
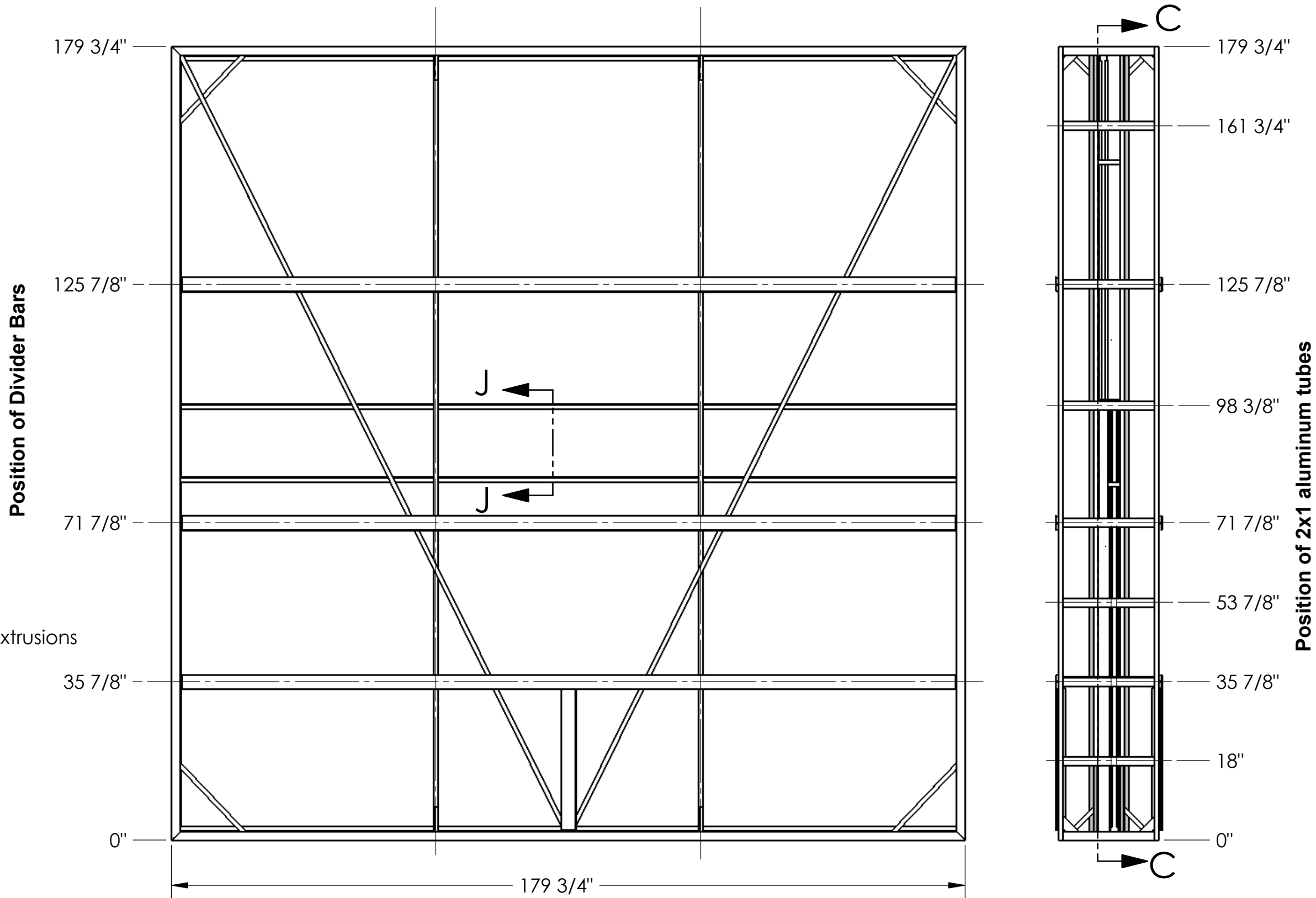

SECTION J-J
SCALE 1 : 9



PROPRIETARY AND CONFIDENTIAL
 This is an original unpublished drawing which is the sole and exclusive property of Sparkle Sign Company, Inc. and is protected under the copyright laws of the United States of America. It was created in conjunction with a project proposed by Sparkle Sign Company, Inc. It is not to be reproduced, duplicated, shown, exhibited, or physically re-created in whole or in part by any individual, group, organization, or entity without the written permission of an officer of Sparkle Sign Company, Incorporated.

DIMENSIONS ARE IN INCHES		NAME	DATE
TOLERANCES:		DRAWN	Mohsen 03/01/06
FRACTIONAL ±		CHECKED	
ANGULAR: MACH ± BEND ±		ENG APPR.	
TWO PLACE DECIMAL ±		MFG APPR.	
THREE PLACE DECIMAL ±		Q.A.	
MATERIAL --		COMMENTS:	
NEXT ASSY	USED ON		
FINISH --			
APPLICATION	DO NOT SCALE DRAWING		

Designed exclusively for:		
CYPRESSWOOD LANDING		
Title:		
Structure		
SIZE	DWG. NO.	REV.
B	C7559-B-01-00	
SCALE: 1:24	WEIGHT:	SHEET 3 OF 4

TOP VIEW

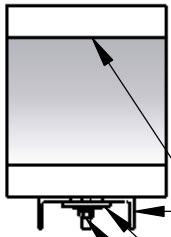
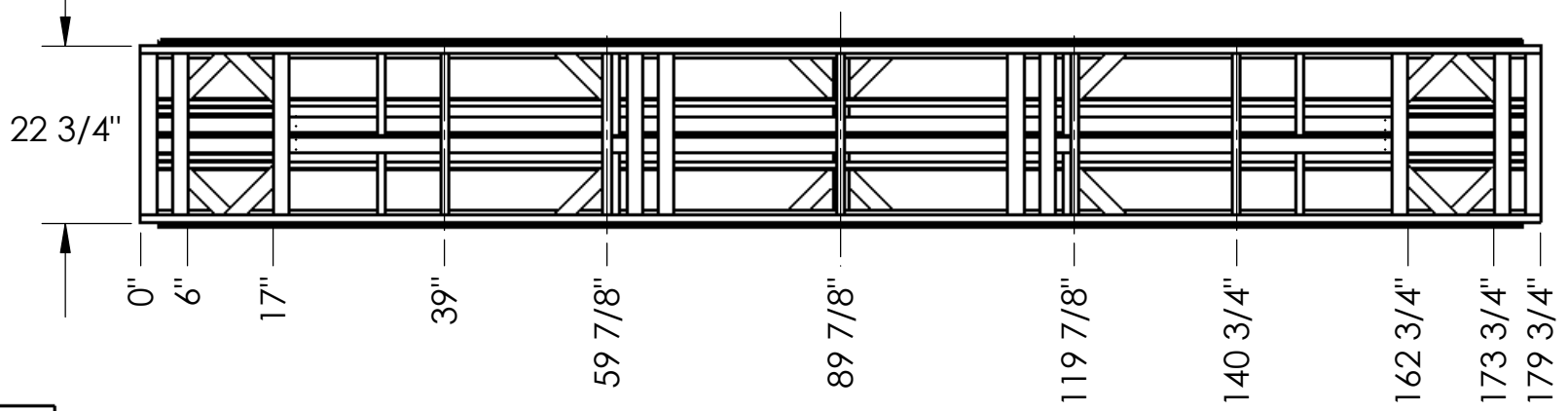

VIEW: The detail of cap attachments

- Cap
- Cabinet Frame Angles
- Plate
- 1/2"-13 Fastener

The position of these angles to be determined according to the size of the foam cap sections.

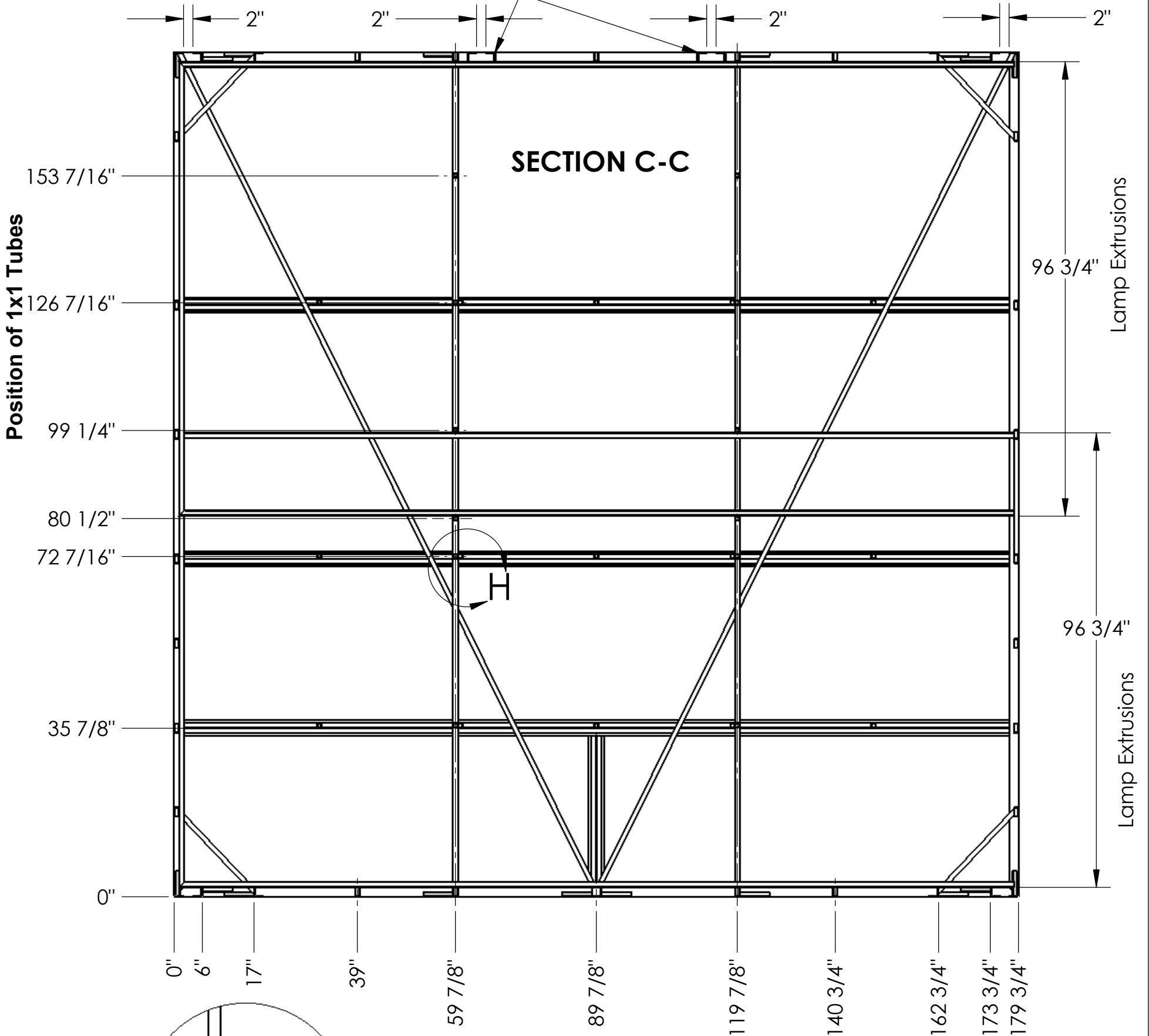

DETAIL H
SCALE 1 : 9

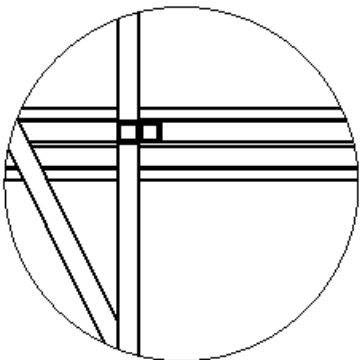

PROPRIETARY AND CONFIDENTIAL

This is an original unpublished drawing which is the sole and exclusive property of Sparkle Sign Company, Inc. and is protected under the copyright laws of the United States of America. It was created in conjunction with a project proposed by Sparkle Sign Company, Inc. It is not to be reproduced, duplicated, shown, exhibited, or physically re-created in whole or in part by any individual, group, organization, or entity without the written permission of an officer of Sparkle Sign Company, Incorporated.

		DIMENSIONS ARE IN INCHES		NAME	DATE
		TOLERANCES:		MOHSEN	03/01/06
		FRACTIONAL ±		CHECKED	
		ANGULAR: MACH ± BEND ±		ENG APPR.	
		TWO PLACE DECIMAL ±		MFG APPR.	
		THREE PLACE DECIMAL ±		COMMENTS:	
NEXT ASSY	USED ON	MATERIAL	--		
		FINISH	--		
APPLICATION	DO NOT SCALE DRAWING				

Designed exclusively for:		
CYPRESSWOOD LANDING		
Title:		
Structure		
SIZE	DWG. NO.	REV.
B	C7559-B-01-00	
SCALE: 1:24	WEIGHT:	SHEET 4 OF 4

